

- Designed by beer-industry experts for performance and value.
- Integrated glass rinser: condition the glass with cold water before pouring.
- Rugged stainless steel keg slides – extends floor life.
- Full-size drain tray – larger work area and improved hygiene.



Black
MDD58



▶ Integrated cold water glass rinser.



Stainless Steel
MDD58S

Feature



Listed by Edison
Testing Laboratories.

Specifications

Micro Matic reserves the right to change specifications without notice.



Part No.	Exterior Finish	Doors	Shipping Weight	Box Dimensions
<input type="checkbox"/> MDD58	Black With Solid Doors	2	156 kg 343 lbs	1537mm L x 762mm W x 1143mm H 60 1/2"L x 30"W x 45"H
<input type="checkbox"/> MDD58S	Stainless Steel With Solid Doors	2	156 kg 343 lbs	1537mm L x 762mm W x 1143mm H 60 1/2"L x 30"W x 45"H

Operating Performance

Capacity of 1/2 Kegs	2	Running Amps	6.5
Cubic Feet (liters)	23.7 (670)	Voltage	115/60/1
Draft Towers	2	Plug Type	NEMA-5-15R
Faucets	3	Cord Length	8'
Beer Tower Approval	NSF 7.0 & NSF 18	Refrigerant	R-134a
Approval	ETL Listed	Charge oz (Grs)	10.5 (300)
Condenser HP	1/3		

Exterior	All Models: 18 gauge stainless steel top, 22 gauge solid doors, 24 gauge steel front, sides and back. Black Models: Front, sides, back and doors are painted black. Stainless Steel Models: Front, sides, back & doors are stainless steel.		
Interior	20 gauge stainless steel floor, 22 gauge corrugated false floor, reinforced frame, 24 gauge galvanized walls		
Ventilation	Front and back ventilated		
Plumbing	Automatic condensate evaporator, no drain connection required. Evaporator condensate has been plumbed to a condensate pan located in the compressor housing.		
Insulation	Foamed-in-place using high density, CFC-free polyurethane; 1-1/2" top, walls and floor.		
Adjustable Legs - Standard	Castors - Optional	6" Legs - Optional	

Dimensions

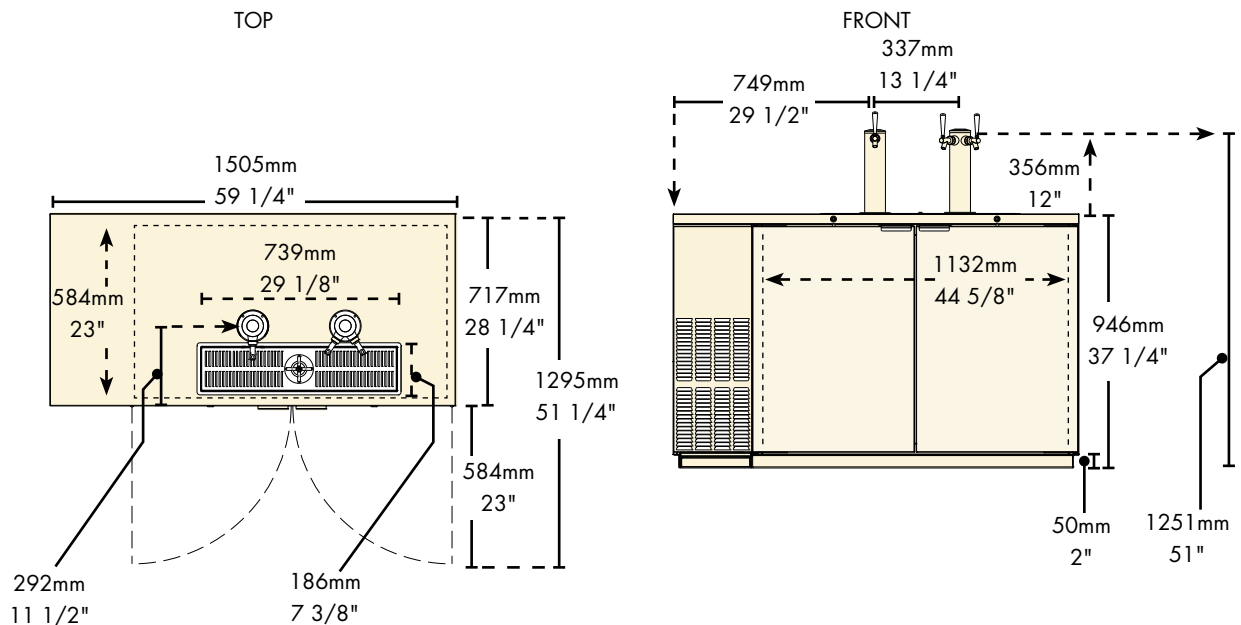

Copyright ©2009 Micro Matic USA, Inc. All Rights Reserved. 00464D0509



www.micromatic.com

Toll Free: 1-(866) 327-4159

West	Central	Southeast	Northeast
19791 Bahama Street Northridge, CA 91324 Tel. (818) 701-9765 Fax. (818) 701-9844	10726 North Second Street Machesney Park, IL 61115 Tel. (815) 968-7557 Fax. (815) 968-0363	2364 Turbine Court Brooksville, FL 34604 Tel. (352) 799-6331 Fax. (352) 796-2429	4601 Saucon Creek Road Center Valley, PA 18034 Tel. (610) 625-4464 Fax. (610) 625-4466