

- Designed by beer-industry experts for performance and value.
- Rugged stainless steel keg slides – extends floor life.
- Full-size drain tray – larger work area and improved hygiene.
- Commercial grade construction – built to last.



Black
MDD23



Stainless Steel
MDD23S

Feature



Listed by Edison
Testing Laboratories.

Part No.	Exterior Finish	Doors	Shipping Weight	Box Dimensions
☐ MDD23	Black	1	75 kg	679mm L x 794mm W x 1194mm H
			165 lbs	26 3/4"L x 31 1/4"W x 47"H
☐ MDD23S	Stainless Steel	1	75 kg	679mm L x 794mm W x 1194mm H
			165 lbs	26 3/4"L x 31 1/4"W x 47"H

Operating Performance

Capacity of 1/2 Kegs	1	Running Amps	2.7
Cubic Feet (liters)	8.4 (239)	Voltage	115/60/1
Number of Draft Towers	1	Plug Type	NEMA-5-15R
Number of Faucets	1	Cord Length	8'
Beer Tower Approval	NSF 7.0 and NSF 18	Refrigerant	R-134a
Approval	ETL Listed	Charge oz (Grs)	10.5 (300)
Condenser HP	1/8		

Exterior	All Models: 18 gauge stainless steel top, 22 gauge solid doors, 24 gauge steel front, sides and back. Black Models: Front, sides, back and doors painted black. Stainless Steel Models: Front, sides, back and doors stainless steel.
Interior	20 gauge stainless steel floor, 22 gauge corrugated false floor, reinforced frame, 24 gauge galvanized walls
Ventilation	Front and back ventilated
Plumbing	Drain Tray: 3/4" NPT drain exits out left end. Automatic condensate evaporator, no drain connection required. Evaporator condensate has been plumbed to a condensate pan located in the compressor housing.
Insulation	Foamed-in-place using high density, CFC-free polyurethane; 1-1/2" top, walls and floor.
Castors - Standard	

Dimensions

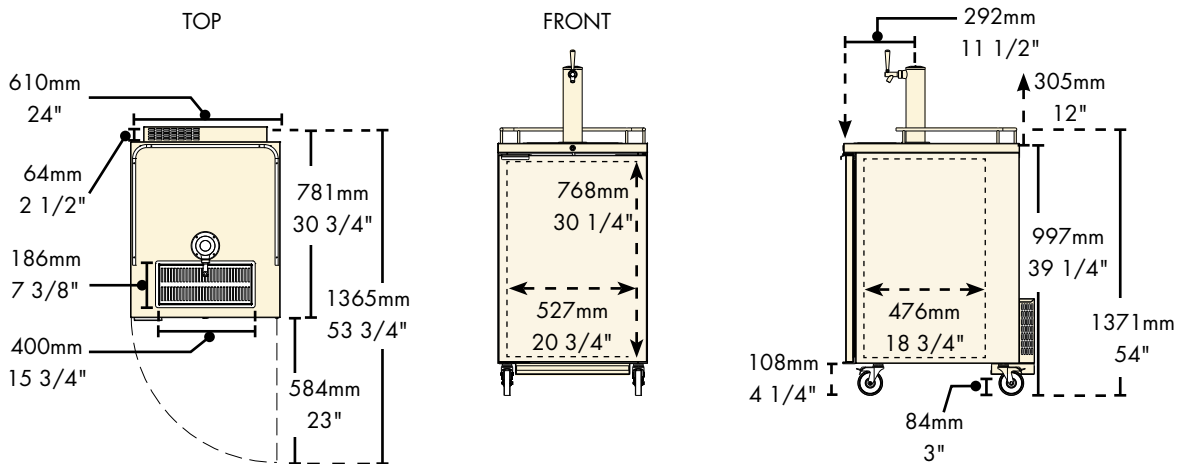

Copyright ©2009 Micro Matic USA, Inc. All Rights Reserved. 00683.D0809



www.micromatic.com

Toll Free: 1-(866) 327-4159

West	Central	Southeast	Northeast
19791 Bahama Street Northridge, CA 91324 Tel. (818) 701-9765 Fax. (818) 701-9844	10726 North Second Street Machesney Park, IL 61115 Tel. (815) 968-7557 Fax. (815) 968-0363	2364 Turbine Court Brooksville, FL 34604 Tel. (352) 799-6331 Fax. (352) 796-2429	4601 Saucon Creek Road Center Valley, PA 18034 Tel. (610) 625-4464 Fax. (610) 625-4466